

FOLDED FOREST

TEAM+SZ_Jung Yuefui, Sun Wantong, Zhuang Yun
College of Architecture and Urban Planning, Tongji University, Shanghai, China



In the morning, walking along the sun-drenched forest paths, watching the beauty of nature, and then at noon, suddenly a little tired and needing a place to rest. The best choice is our Visitor Center. The design is based on the "Z" shape of the building, which integrates the building into the mountain and forest and folds nature into the building. In the pavilion, there are kinds of activities to provide leisure and entertainment places, tea room to sip tea, reading room to read, exhibition hall to see the exhibition, the body and mind to relax.

Idea and Concept

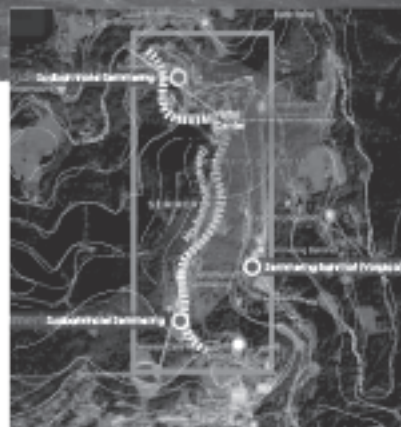
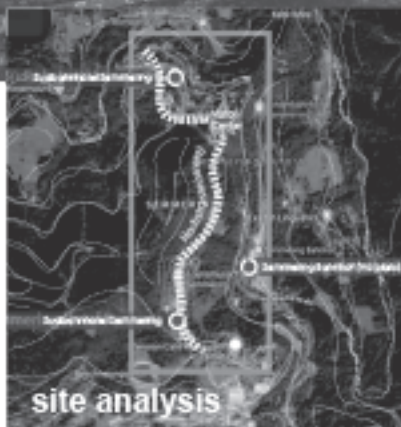

Concept Analysis

Step 1
Four boxes

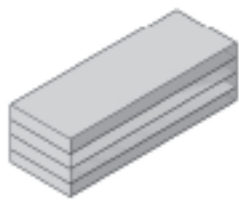

Step 2
Stagger the boxes

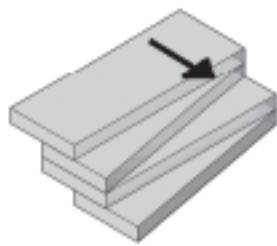

Step 3
Lifting boxes

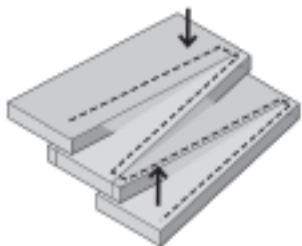

Step 4
Stagger again

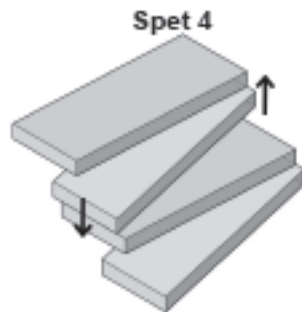

Step 5
Add contents and trees

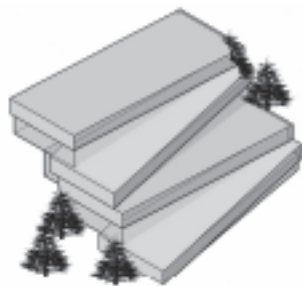

Step 6
Arrange traffic

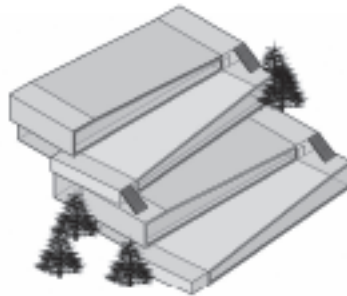

SITE PALN
1:1000

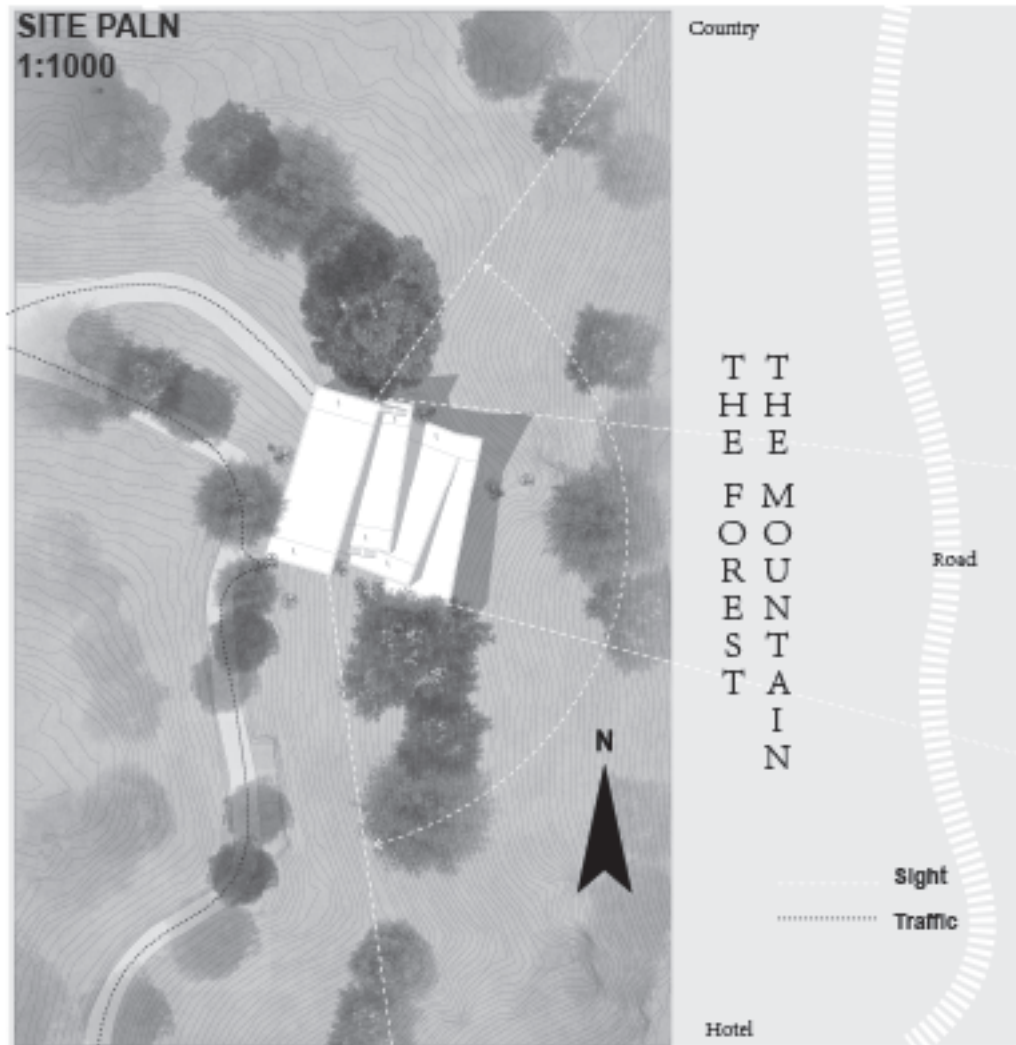

PALN I
1:500



PALN II
1:500



PALN III
1:500



PALN IV
1:500

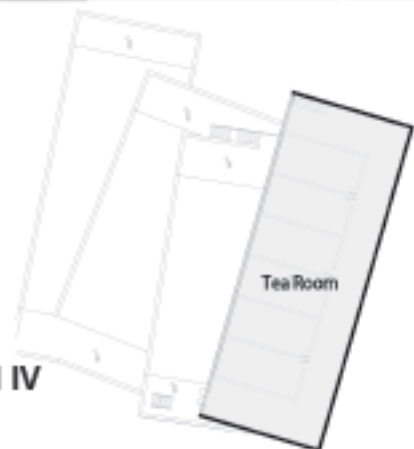

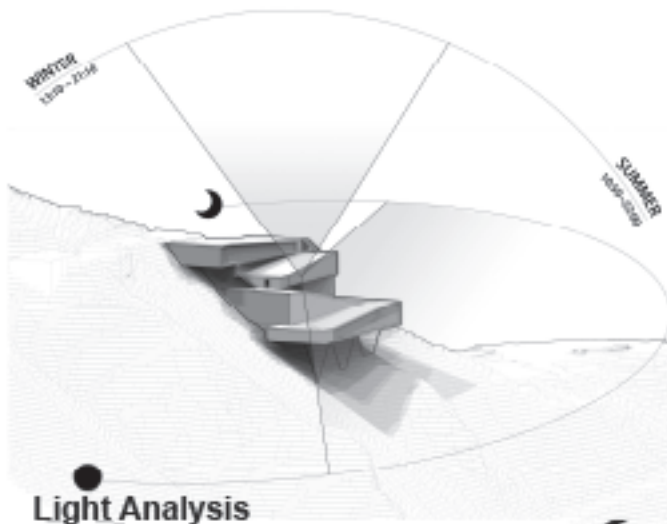

Light Analysis

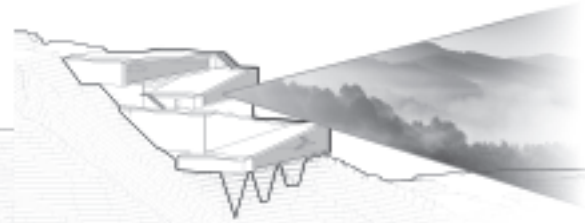

Sight Analysis

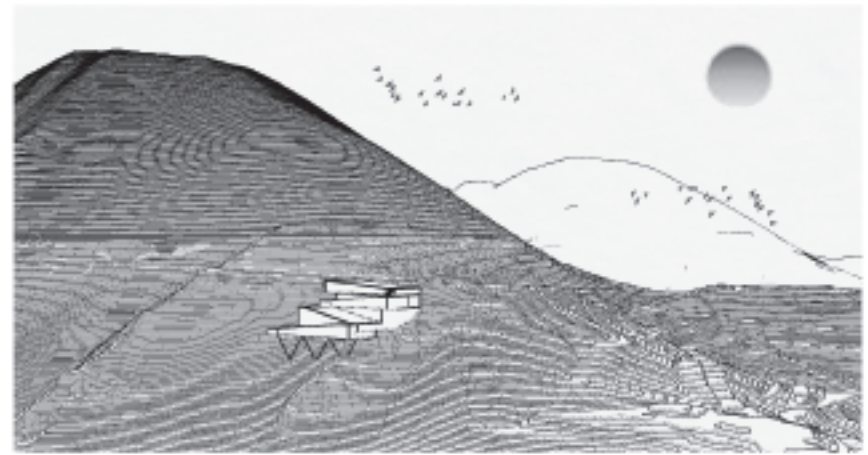

Cross-sectional Plan

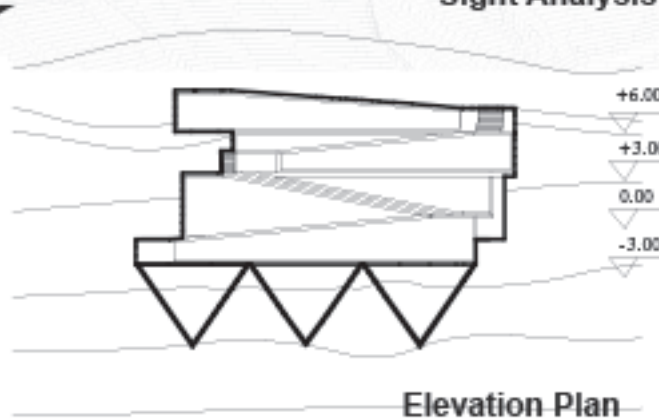

Elevation Plan



North View

WELL!!! Right here!!!
Let's go to the visitor center.
I hear that there is an exhibition of the local herbs!!!



WOW!!! Right here!!!
It has somewhere to take a break.
The visitor center is not far. Wonderful!



Take care! The terrain is a bit steep!



South View

Take care! The terrain is a bit steep!