

Flowing moments

FINE

Eunhee JOO

Department of Architecture, Pusan National University, Busan, Korea

Sungsu KIM

Department of Architecture, Pusan National University, Busan, Korea

Dakyeong Lee

Department of Architecture, Pusan National University, Busan, Korea

Yeonju Lee

Department of Architecture, Pusan National University, Busan, Korea

PROLOGUE

Of course, we are not Italians. As foreigners, the scenes in the movie are not similar our hometown. However, we could feel the 'nostalgia' from the movie set in a particular village in a foreign country.

Yes, 'Cinema Paradiso' is famous for making people feel nostalgia. But why?

PHILOSOPHY

From the movie, people recognize the flow of time through music, sound effects, and video techniques. The film turn into a non-burnt material. In dramatic situations, the scene overlap the grown-Salvatore, who recalled memories with a serious face with music. The upstairs-people who often spit to the downstairs-people were covered by dirt.

All these are the devices that recognize that the past have passed.



The film turns into a non-burnt material.



The screen changes to the grown man.



The spit-man covered by dirt.

This is the point of 'nostalgia'. Like this, artwork reflects each experiences of people through stimulation of five senses. So we can get impression beyond the barriers of language, generation, gender, etc.

We all have our own hometown. There are times when each person wants to go back. But we know that the moment is passed and does not come back. People recognize that time is irreversible, so they feel beautiful and a little sorrowful nostalgia.

We hope that the site will be a place where visitors can feel this.

IDEA



senses.

Recognizing flowing moments

So, we intend visitors to recognize and expand the 'flowing moment' here. Then we can express our feelings about the movie well(nostalgia), and the visitors can sympathize with it.

Stimulating the five senses

The strong stimuli for nostalgia include smell, touch, music, and weather. Outside(natural space), you can feel these stimuli most immediately. Temperature, humidity, smell, touch. We call this weather. The wind that grazed the flesh, the smell of soil, and the dazzling sunshine.

We enrich the nature space without disturbing the landscape so that visitors can feel intensified stimuli through the five

LAYOUT PLOT

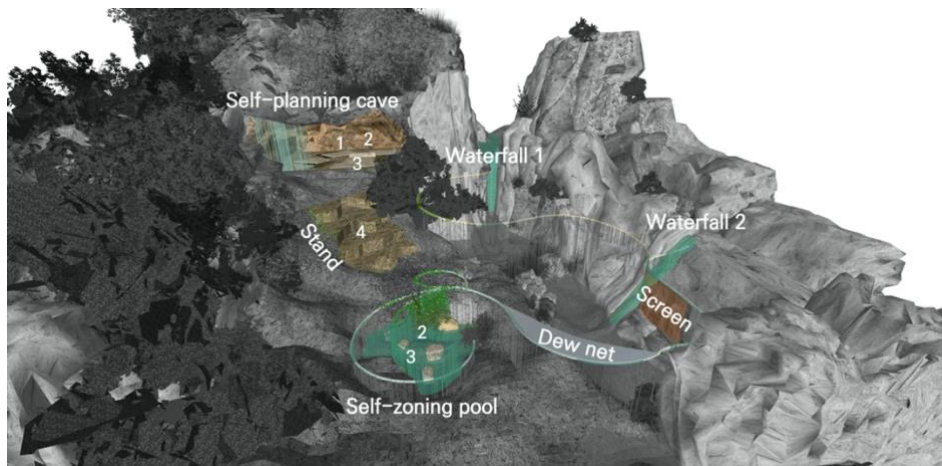

PROGRAM

1. Bedding
2. Dining
3. Conference
4. Watching.

METHODOLOGY

We select 'natural elements' for the architectural implementation of this idea and use the principle of elements to expand or differentiate the natural space.

Water_Flowing



The attractive waterfall inspired us. The water is always flowing by our side. It resembles the flow of time. It seems to be circulating, but just as yesterday's rain is different from today's rain, the past moments never come back.

We extend the property of water that resembles the property of time. The water flows from top to bottom, shining, making sounds, and emitting cool air. Through this natural method, visitors are stimulated by the five senses and recognize and enjoy the flowing moments.

Soil_Leveling



In this natural space, the soil provides a floor for us to overcome. This is the most basic and stable element of architecture. We take advantage of the good to modeling but solid properties of soil. Wide, narrow, deep and shallow levels of ground increase the potential to utilize, which increases space experience.

USAGE PLAN

Self-Planning Cave

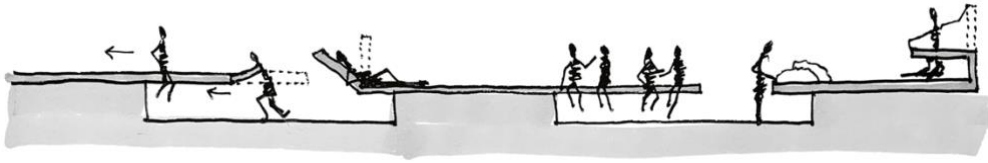

A Leveled ground and movable & foldable board create the potential for space use..

Bedding	Dining	Conference Type 1	Conference Type 2
<p>Water curtain</p>	<p>Washing</p>	<p>Screen</p>	<p>Screen</p>

Self-Zoning Pool

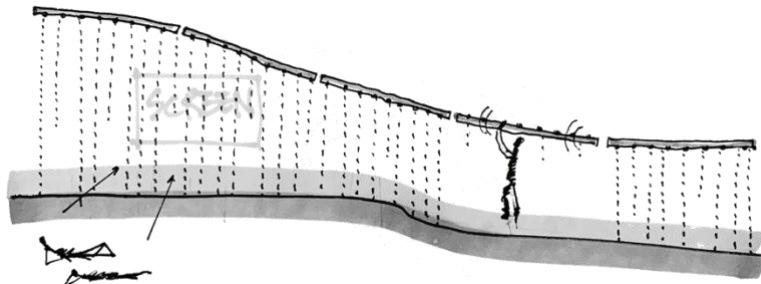

*Flowing water curtain becomes a screen of movies and filter of landscape.
The area of water curtain is controlled by the user rolling the pipes of water curtain.*

Small-scale Interaction	Large-scale Interaction	Multi-dimensional Interaction
	<p>CINEMA SCREEN</p>	

Dew Net

During the night

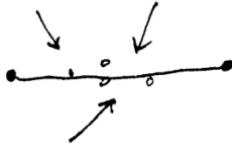

At dawn

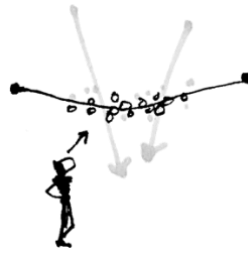

During the day

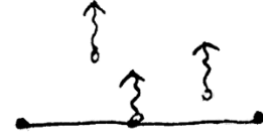

CONDITIONS

Water Curtain

- The path starts with waterfall and ends with stagnant water on the ground.
- The area where the water curtain flows permanently is selected as the areas where the view from the path can be the most dramatic.

Dew Net

- It is located in the entrance which is at the beginning and end of the experience.
- Select a place that does not interfere with the role of the water curtain as a screen.

Stands

- The shape should be constructed to follow the existing ridges and view the screen and landscape.
- Set the depth and width at which the stairs can function freely as the seat and the ground.

STRUCTURAL DETAILS

Water Curtain



Pipes connected to rock face.

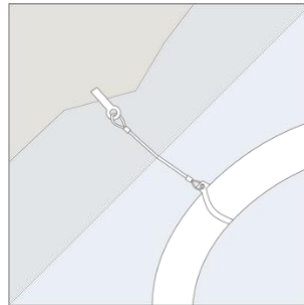

Wire ropes connect the rock face to the pipes.

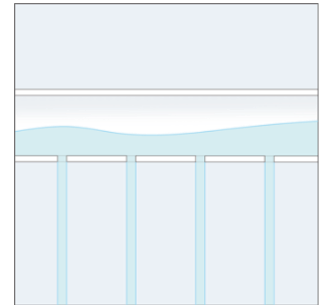

Spill the water through hole in pipe.

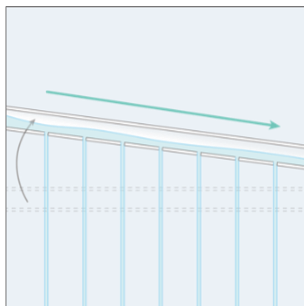

Slope the path so that water flows continuously.

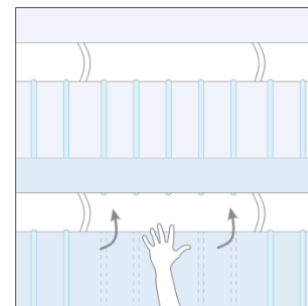

Roll the units of pipes to control the area of water curtain.

Self-Planning Cave

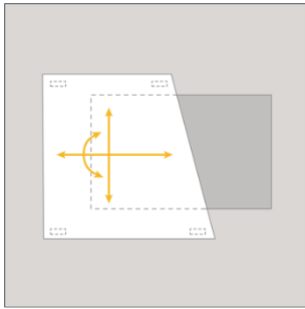

Free movements of the boards

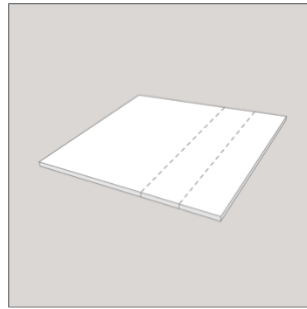

Fixable wheels

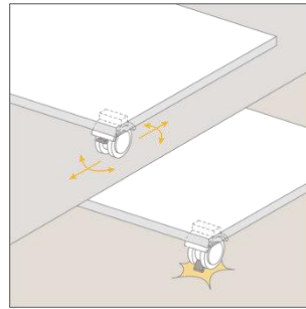

Foldable boards

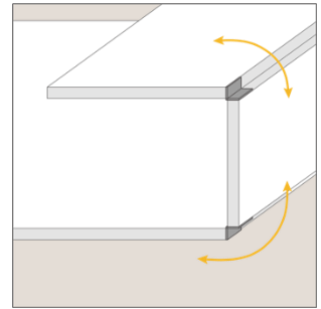

Transform and Fix with hinges

Dew Net

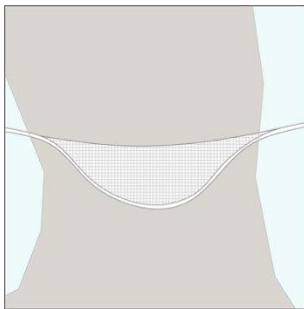

A dew net hanging from pipes

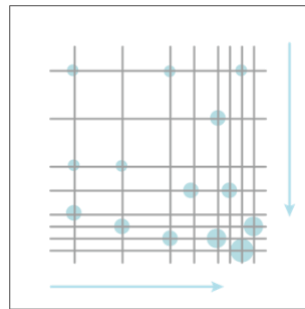

Adjust the density of holes to collect dew.

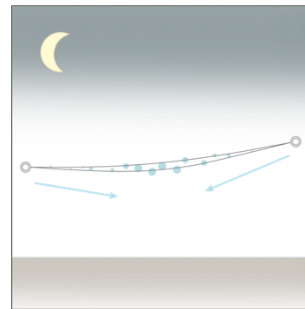

As the center becomes heavier, the dew gets bigger during the night.

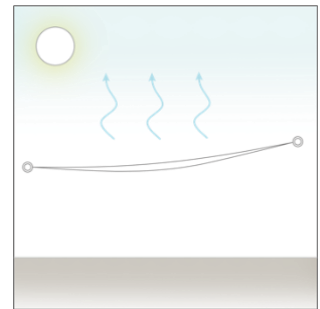

Dew evaporates during the day and disappears.

F.I.N.E.